

WEST LOS ANGELES PURCHASE OPPORTUNITY

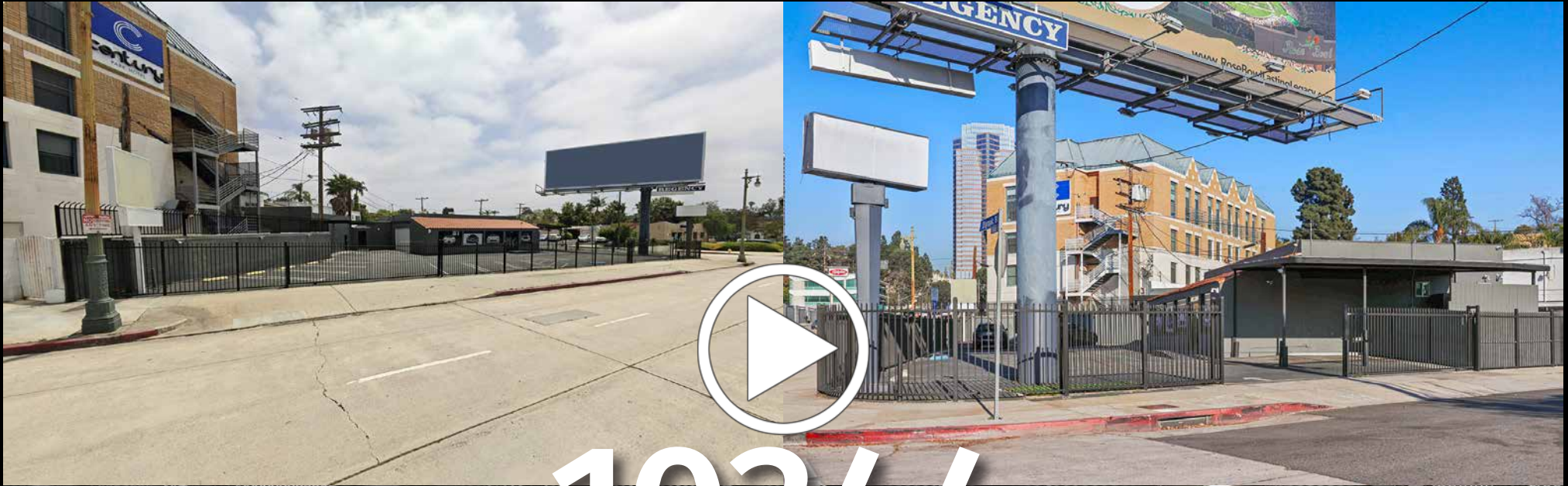

10344
olympic



Heavy Traffic Retail Storefront Property
2,450± SF Building on 9,070± SF of Land

**10344-10355 W OLYMPIC BLVD
LOS ANGELES, CA 90064**

Property Details

Building Area:	2,450± SF
Building 1 Area:	1,850± SF
Building 2 Area:	600± SF
Stories:	One
Land Area:	9,070± SF
Year Built:	1951
Parking:	10± striped surface spaces
Zoning:	LAC2-1VL-O
APN:	4315-018-049
Frontage:	132' on Olympic Blvd 87' on Bellwood Ave
Traffic Count	58,000 vehicles per day (2022)
TOC:	Not Eligible
Opportunity Zone:	No

Property Highlights

- Owner/user or development purchase opportunity
- Prime West Los Angeles location just west of Century City and adjacent to Beverly Hills
- C2 zoning uses include retail, office, hotel/motel, automotive uses, recreational uses, daycare, schools, religious use, community center, etc.
- Also ideal for mixed-use or multi-family development
- Former auto dealership
- Fantastic exposure and signage with very heavy vehicle traffic

PROPERTY AMENITIES INCLUDE:

- Visitor lounge
- Office/lounge
- 2 restrooms
- 2 outside break areas plus a pet area
- 2 car garage
- Secure gated lot with striped parking for 10 vehicles
- Includes \$5,300/month billboard income (mo.-mo.)

Sale Price: \$6,950,000 (\$766.26 Per SF Land)

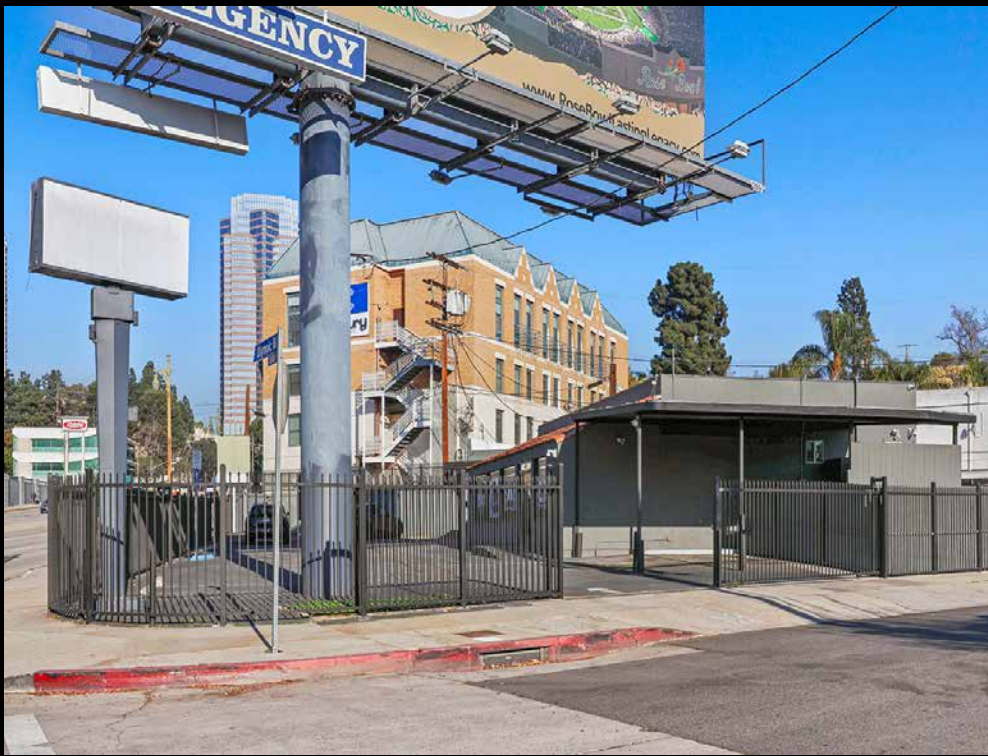





Property Aerial

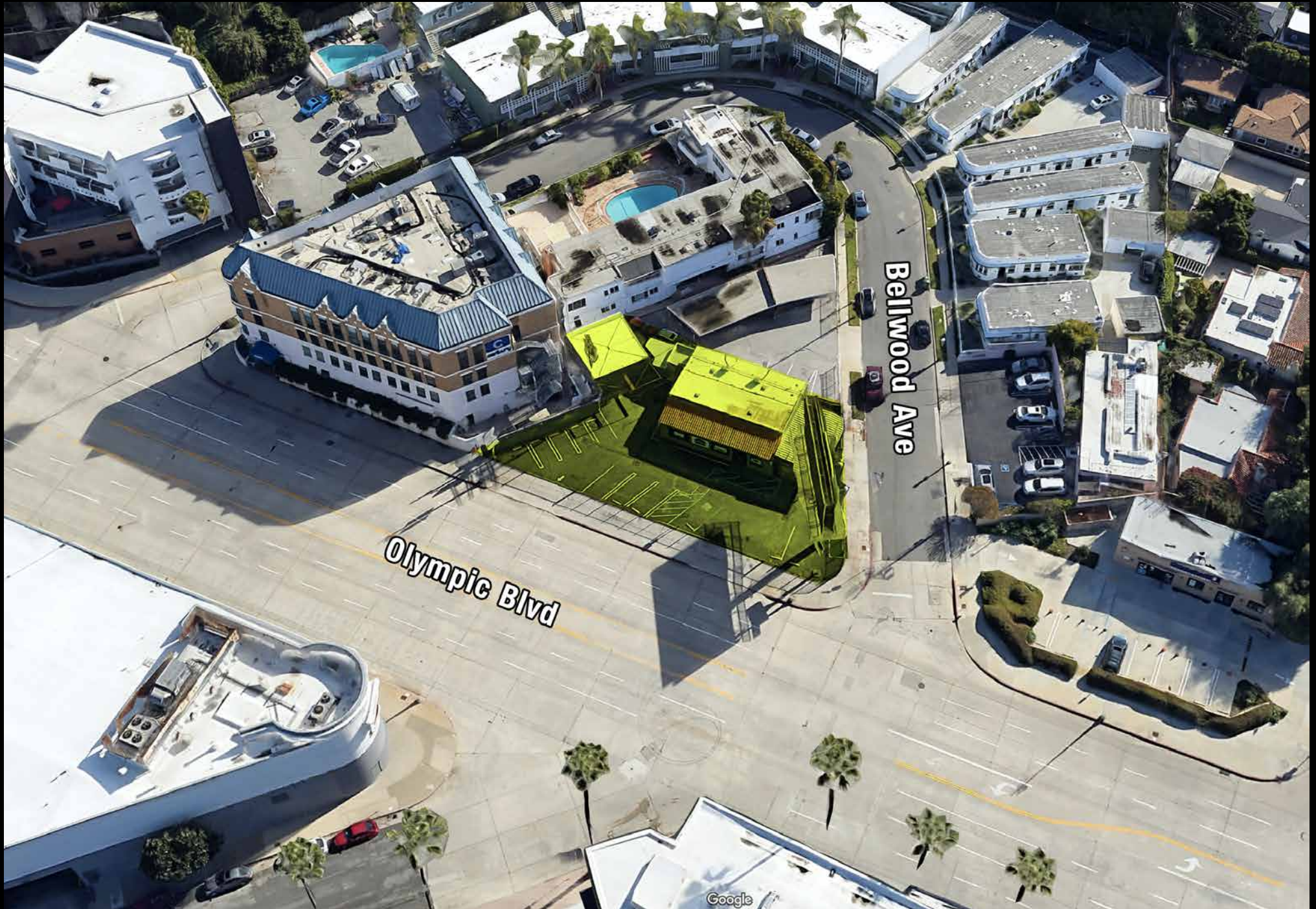

Plat Map



BK.
4319

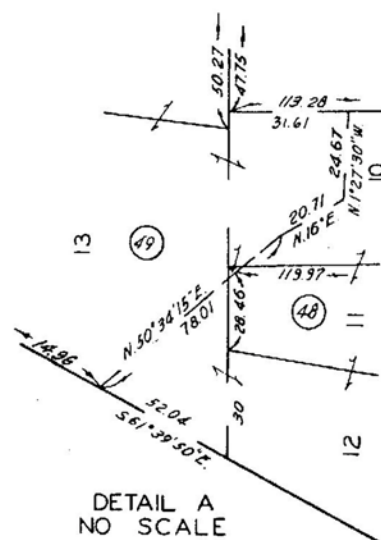
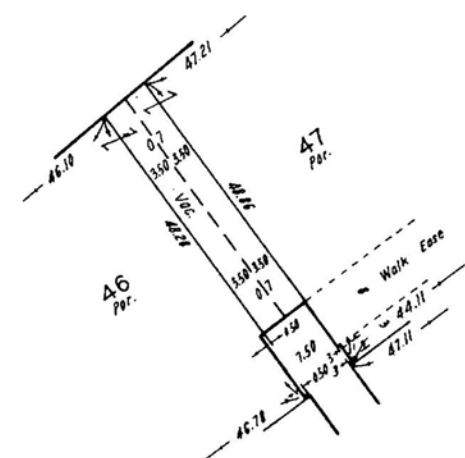
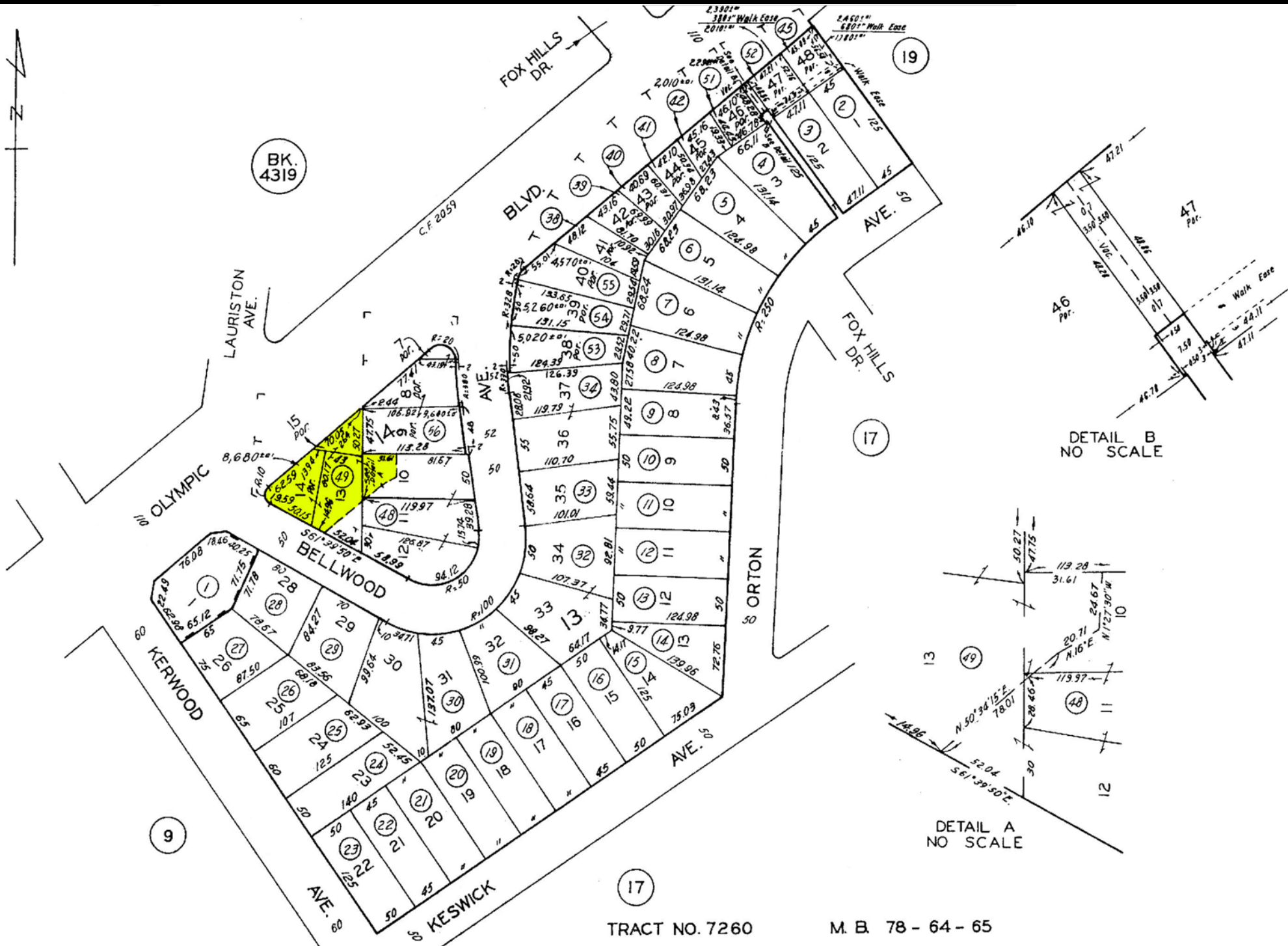

TRACT NO. 7260

M. B. 78 - 64 - 65

Area Map

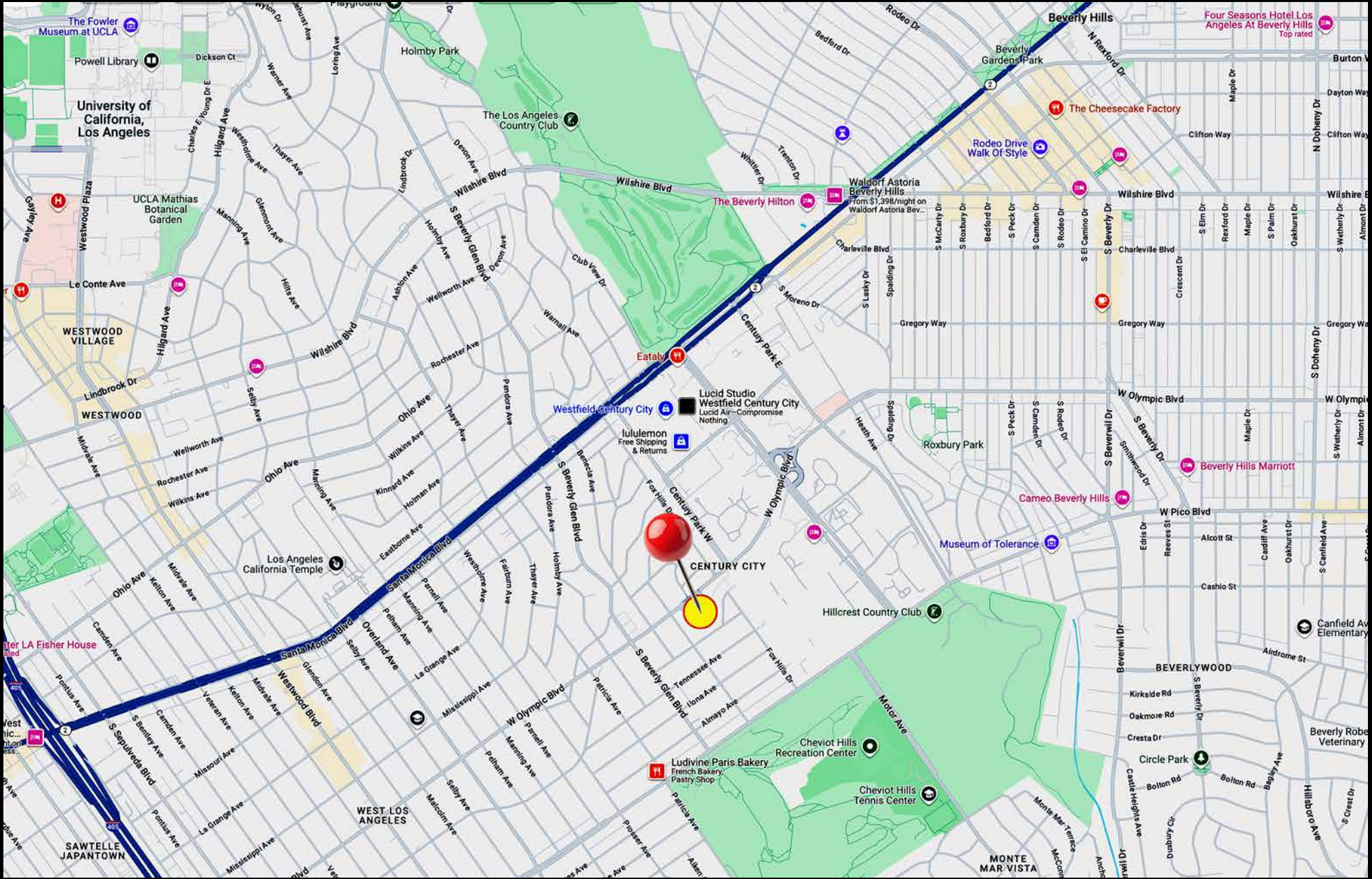

Amenities Aerial

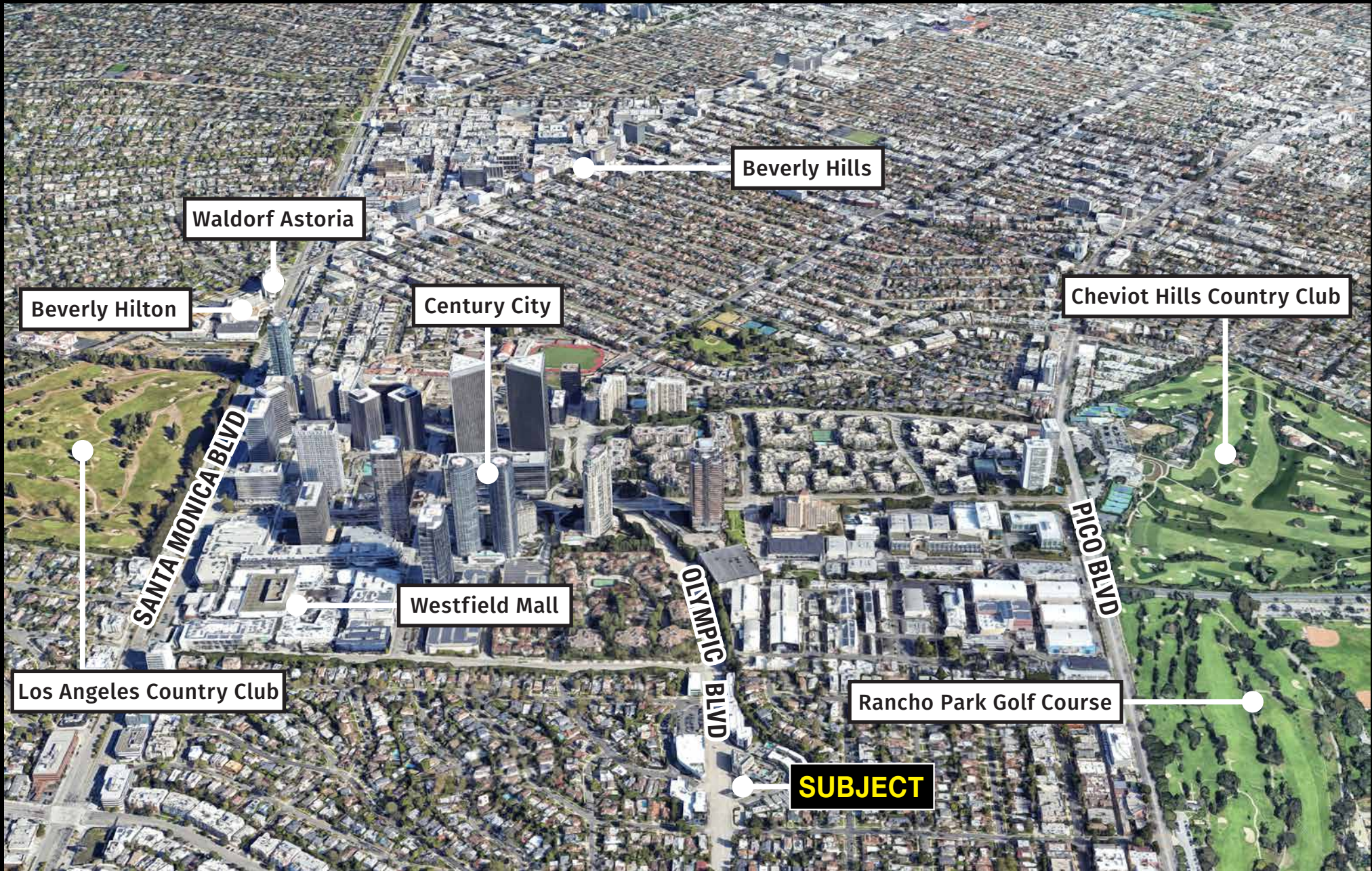

About Century City

HISTORY

Century City, located on the west side of Los Angeles, was established in the mid-20th century on land that was once part of the 20th Century Fox backlot. In the 1960s, developers turned this area into a business hub, envisioning it as a “city within a city.” Over time, it evolved into a thriving district known for its skyscrapers, luxury amenities, and proximity to Beverly Hills. Century City is a vibrant blend of business, and entertainment. Its rich history as part of Hollywood’s golden age has transitioned into a modern community that caters to both work and leisure, making it one of Los Angeles’ most desirable neighborhoods.

BUSINESS AND ENTERTAINMENT HUB

Century City is a major commercial district with a concentration of law firms, financial institutions, and entertainment companies.

It is home to Fox Studios, a legacy of the area’s film industry roots, and headquarters for various media and tech companies.

LUXURY HOTELS

Fairmont Century Plaza: An iconic luxury hotel featuring a blend of historical architecture and modern amenities.

InterContinental Los Angeles Century City: Known for its upscale accommodations and proximity to key attractions.

Waldorf Astoria Beverly Hills: Though technically in Beverly Hills, it’s a short distance away and offers high-end lodging.

SHOPPING AND DINING

Westfield Century City: A premier shopping destination with luxury retailers, a modern movie theater, and diverse dining options. Brands like Louis Vuitton, Gucci, and Apple anchor the mall.

Restaurants range from casual eateries to fine dining, with options like Eataly and Din Tai Fung.



RECREATIONAL AMENITIES

Century City is designed for professionals and residents alike, with beautifully landscaped parks and open spaces.

The district features modern fitness centers, wellness studios, and a vibrant nightlife scene.

ATTRACTIONS NEARBY

Beverly Hills: Minutes away with world-class shopping on Rodeo Drive.

Santa Monica: A short drive west, featuring the beach and pier.

Museum Row: On Wilshire Boulevard, home to the Los Angeles County Museum of Art (LACMA) and the Petersen Automotive Museum.

REAL ESTATE AND LIVING

Century City is a prestigious residential area with luxury condominiums and apartments. Iconic residential towers like The Century and Ten Thousand offer high-end living with panoramic views of Los Angeles. The neighborhood is popular among professionals and celebrities due to its central location and exclusivity.

Neighborhood Demographics

Household Income

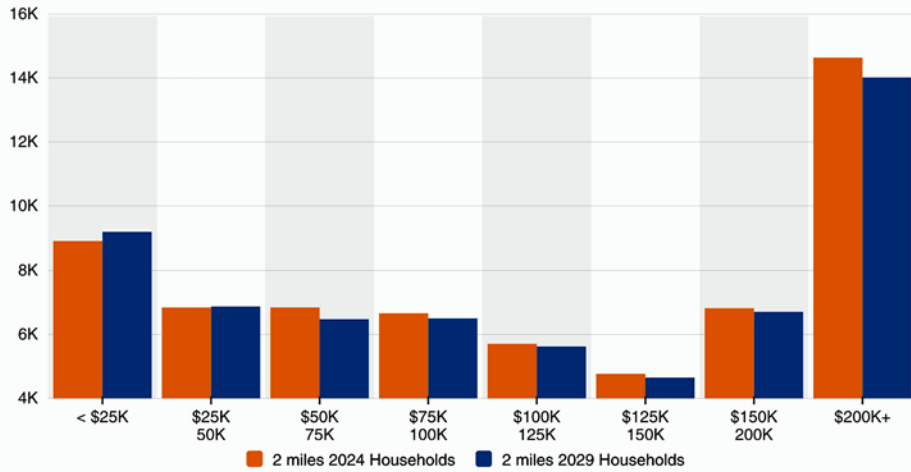

Household Income By Age

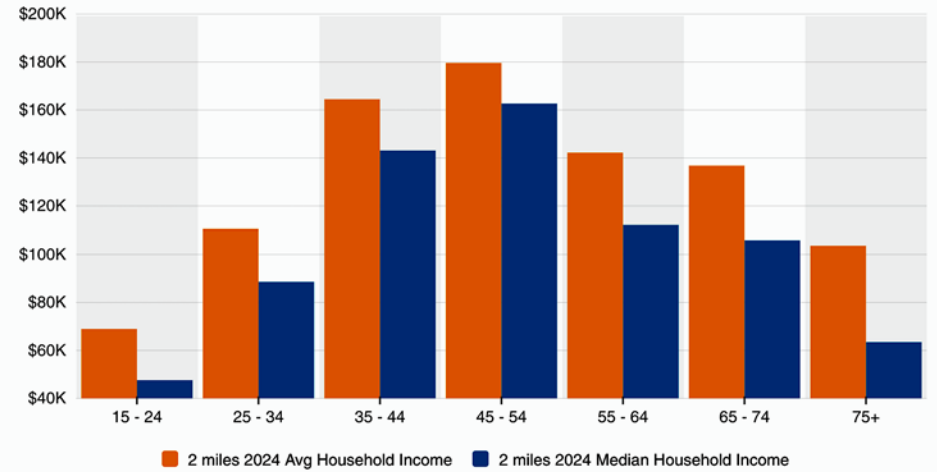

Housing Occupancy

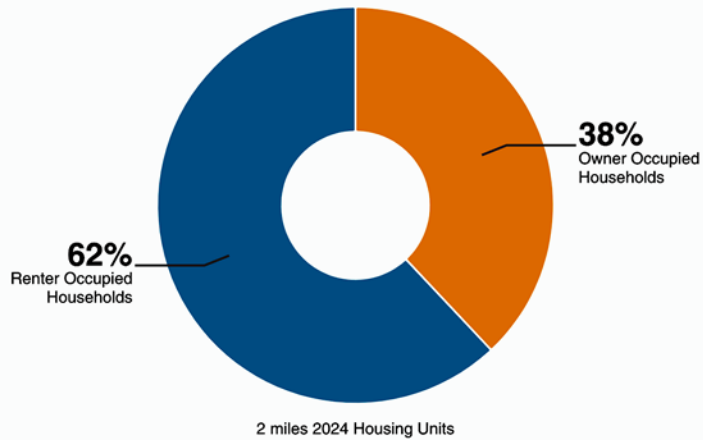

Home Values

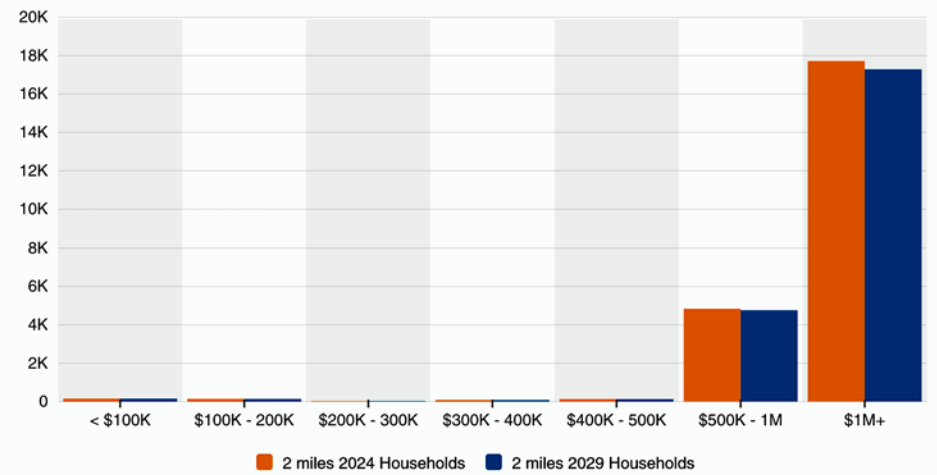

**10344-10355 W Olympic Blvd
Los Angeles, CA 90064**

**2,450± Sq.Ft. of Buildings
9,070± Sq.Ft. of Land**

**Owner/User or Development
Purchase Opportunity**

Prime West Los Angeles Location

Exclusively offered by



Bradley A Luster
President

213.747.4154 office

213.276.2483 mobile

brad@majorproperties.com

Lic. 00913803



Samuel P Luster
Sales Associate

213.222.1200 office

818.584.4344 mobile

sam@majorproperties.com

Lic. 02012790

MAJOR PROPERTIES

**1200 W Olympic Blvd
Los Angeles, CA 90015**

The information contained in this offering material is confidential and furnished solely for the purpose of a review by prospective Buyers of the subject property and is not to be used for any other purpose or made available to any other person without the express written consent of Major Properties.

This Brochure was prepared by Major Properties. It contains summary information pertaining to the Property and does not purport to be all-inclusive or to contain all of the information that a prospective Buyer may desire. All information is provided for general reference purposes only and is subject to change. The summaries do not purport to be complete or accurate descriptions of the full documents involved, nor do they constitute a legal analysis of such documents.

This information has been secured from sources we believe to be reliable. We make no representations or warranties, expressed or implied, as to the accuracy of the information. References to square footage or age are approximate. Recipient of this report must verify the information and bears all risk for any inaccuracies.